

CUTTER BARS

KEENCUT

THE WORLD'S FINEST CUTTING MACHINES



CUTTER BARS



**SHEET
MATERIAL
CUTTERS**

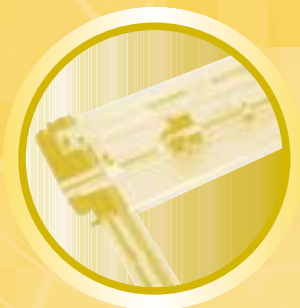

MAT CUTTERS



ROTARY CUTTERS



Keencut's extensive range of cutter bars offer a standard of straight, square and clean cutting that is impossible to achieve with a craft knife and straight edge. Whether used alone as a moveable unit, with the optional Lift & Hold mechanisms ① or in conjunction with the Keencut BIG bench ② these simple no-nonsense cutter bars offer an ingenious cutting solution that is safe for both product and people.

All cutter bars share the same cutting head that features a blade depth adjustment ③ as standard and safely retracts the blade when not in use. Standard utility blades ④ will cut to a depth of 10mm (0.4") and special long reach blades will cut 13mm (0.5"). The patented linear bearings have been test run under load for 1600 km (1000 miles) with the result that they are guaranteed for 20 years, two full length silicon rubber grip strips on the underside ensures all work is held perfectly in place while cutting and provides protection for the most sensitive of surfaces. All cutter bars can be lifted and stored safely on the wall brackets provided.

To use alone, simply place the cutter bar on the material to be cut, align it with the image registration or crop marks, depress the cutting head and push ⑤ or pull ⑥ it along to cut. Add the optional surface mounted Lift & Hold mechanisms ① and you can easily align and trim the largest work singlehanded, combine with the BIG bench ② and you create the ultimate precision cutting table.

◀ JAVELIN

The unique design of the Javelin enables its straightness to be factory adjusted using laser technology. Guaranteed straight to within 0.2mm (0.008") it meets today's very high standards for accurate butt joints on sectional panels, trade show graphics and pop-up systems.

Practik

GENERAL PURPOSE CUTTER

Where less extreme accuracy is required, the innovative design of the Practik provides an economical alternative with a guaranteed straightness of 1.00mm (0.039") making it an ideal general purpose cutter.

KEENCUT max

CUTTER BAR

Where the requirement is to cut materials wider than 3m (120") the inbuilt rigidity of the Max allows the cutter bar to span the output of all "super-wide" format printers.

IDEAL FOR CUTTING

- PVC Foamboard up to 6mm (0.25")
- Foam centred board up to 13mm (0.5") *
- Honeycomb and corrugated plastics
- Vinyl and Plastic film
- Cardboard
- Corrugated cardboard

* 10mm (0.4") with standard blade, 13mm (0.5") with long reach blade.

IDEAL FOR SCORING

- Acrylics and Perspex **

** Using optional scoring blade.



Superbly styled, the Sabre is essentially a Practik cutter bar with its own integral base. The extruded and silver anodised aluminium base incorporates a narrow groove to accept the blade tip when cutting, a full length silicon rubber grip strip mounted in the surface of the base and two more on the underside of the cutter bar ensures all work is held perfectly in place while cutting and provides protection for even the most sensitive surfaces.

The innovative hinge and lift arm mechanism ⑦ not only makes it possible to cut materials which are longer than the length of the cutter, it allows the Sabre to accept materials up to 13mm (0.5") without affecting either the line or angle of cut, the latter always remaining perfectly vertical.

Efficiently engineered for volume production, the Sabre offers the same cutting capacities as the Practik and embodies the highest standards of design excellence combined with outstanding value for money.

OPTIONAL ACCESSORIES

- Extended measuring arm 914mm (36")
- ⑧ Stand
- Waste Catcher
- Roll Dispenser

An accurate full length metric/imperial measuring scale is fitted as standard equipment



The combination of the BIG bench with the choice of Keencut's Javelin, Practik or Max cutter bars creates the ultimate precision cutting table.

The stability of the BIG bench, with individual level adjustment on each leg, provides a firm and flat work surface to ensure extreme accuracy and the integral Lift and Hold mechanism enables the largest work to be aligned and trimmed singlehanded. The Cutter Bars can be lifted and stored safely on wall brackets if the table is needed for other tasks and re-installation is simple using the precise built in location devices, no tools are required.

The aluminium table edge extrusion incorporates a cutting base with a narrow groove to accept the blade tip while cutting, an accurate metric/imperial measuring scale is fitted as standard and a full length silicon rubber grip strip mounted in the surface of the table edge ensures all work is held perfectly in place while cutting and protects the most sensitive surfaces.

The edge of the table extrusion accepts optional clip on support arms to increase the effective working area just when it is needed.

Supplied flat-packed, self assembly is simple and as part of Keencut's Proteus range of workplace equipment the BIG bench can be extended and added to at any time.





	1.0 KJ01	1.5 KJ02	2.0 KJ03	2.5 KJ04	3.0 KJ05
✂ A cm (")	100 (40)	150 (60)	200 (80)	250 (100)	300 (120)
B cm (")	117 (46)	167 (65.75)	217 (85.5)	267 (105.25)	317 (124.75)



	1.0 KP01	1.5 KP02	2.0 KP03	2.5 KP04	3.0 KP05
✂ A cm (")	100 (40)	150 (60)	200 (80)	250 (100)	300 (120)
B cm (")	117 (46)	167 (65.75)	217 (85.5)	267 (105.25)	317 (124.75)



	3.5 KM01	4.0 KM02	4.5 KM03	5.0 KM04
✂ A cm (")	350 (140)	400 (160)	450 (180)	500 (200)
B cm (")	372 (146.5)	422 (166.25)	472 (186)	522 (205.5)

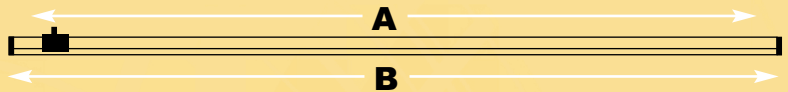

	1.0 KS11	1.5 KS12	2.0 KS13	2.5 KS14	3.0 KS15
✂ A cm (")	100 (40)	150 (60)	200 (80)	250 (100)	300 (120)
B cm (")	118 (46.5)	168 (66)	218 (85.75)	268 (105.5)	318 (125)

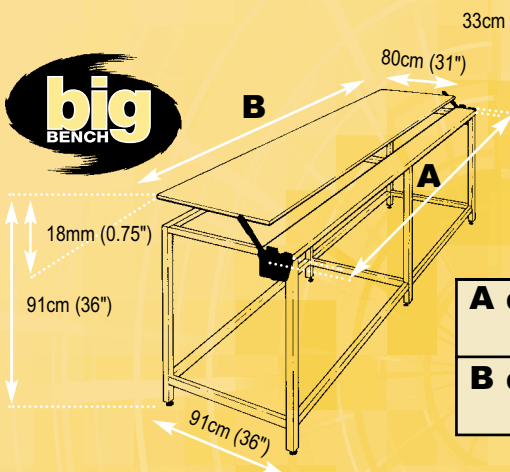
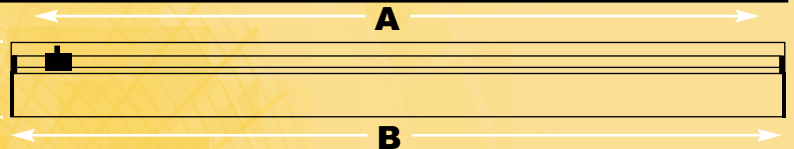

	1.0 KB01	1.5 KB02	2.0 KB03	2.5 KB04	3.0 KB05	3.5 KB06	4.0 KB07	4.5 KB08	5.0 KB09
A cm (")	125 (49)	175 (69)	225 (88)	275 (108)	325 (128)	380 (149.75)	430 (169.5)	480 (189)	530 (208.75)
B cm (")	115 (45)	165 (65)	215 (84.50)	265 (104)	315 (124)	370 (145.75)	420 (165.5)	470 (185)	520 (204.75)

Guarantees

- 5 year comprehensive guarantee
- 20 year free replacement guarantee on all bearings
- 30 day, no quibble, money back guarantee



THE WORLD'S FINEST CUTTING MACHINES

KEENCUT LIMITED
Tel: +44 (0)1536 263158 Fax: +44 (0)1536 204227 E-Mail: sales@keencut.co.uk
Baird Road Willowbrook Industrial Estate, Corby, Northants, England NN17 5ZA.

KEENCUT INC. (North American Sales)
Toll Free: 1 800 240 KEEN (5336) Tel: 1 (519) 652 0970 Fax: 1 (519) 652 0396
E-Mail: northamericansales@keencut.com
366-3560 Pine Grove Ave. Port Huron, Michigan, 48060 USA

Full KEENCUT Product Range

- Cutter Bars
- Sheet Material Cutters
- Rotary Cutters
- Mat Cutters



www.keencut.co.uk